

FOX VALLEY TOOL & DIE, INC.

Press Specifications

Press	Komatsu OBW200 (2 presses)	Komatsu H1F200 CS	Komatsu H1F200-2	Komatsu H1F200-2	Komatsu H1F200-2	Komatsu H2W 300 (2 presses)	Pacific 250PF- OBS (2 presses)	Pacific 400D10-48	Minster GS2-400
Tonnage	220	220	220	220	220	330	250	400	440
Shut Height (SDAU)	16.68**	17.72	17.72	17.72	17.72	23.6	12	15	29
Stroke	9.84	9.84	11.8 / 1.18	11.8 / 1.18	11.8 / 1.18	11.8 / 5.9	10	18	13.8
Ram Adjustment	4.72	4.72	4.72	4.72	4.72	7.8	adj.	adj.	9.8
Strokes/Min.	30-50	20-50	50 /124	50 /124	40 / 62	40 / 55	n/a	n/a	53 / 110
Ram Area Depth x Width	26 x 73	26 x 34	26 x 34	26 x 34	26 x 34	47 x 82	34 x 58	48 x 120	55 x 120
Bolster Area Depth x Width	34 x 95	33 x 57	33 x 57	33 x 57	33 x 57	47 x 94	34 x 58	48 x 120	55 x 120
Feed Line Height	8 +/-4	n/a	8 +/-4	8 +/-4	8 +/-4	12 +/-64	n/a	n/a	8 + 12
Feed Line Rating	.187 x 24	n/a	.156 x 12	.187 x 24	.187 x 18	.281 x 24 .375 x 12 .500 x 8	n/a	n/a	.139 x 48
Coil Weight Max.	10,000	n/a	6,500	6,500	6,500	15,000	n/a	n/a	30,000
Air Cushion	n/a	n/a	n/a	n/a	n/a	n/a	yes	yes	n/a
A.C. Tonnage	n/a	n/a	n/a	n/a	n/a	n/a	75	135*	n/a
Ram Knockout	yes	yes	yes	yes	yes	yes	yes	yes	no
Press Type	Mech.	Servo	Servo	Servo	Servo	Servo	Hyd.	Hyd.	Servo

*400 ton Pacific has three cushions @ 45 tons each
 **Dimensions reflect 3" plate mounted to ram

FOX VALLEY TOOL & DIE, INC.

Coil Specifications & Packaging Instructions

Coil Specifications:

- ID 17-20"
- OD 65" Maximum (48" Preferred Minimum)
- 10,000# Maximum Coil Weight *unless otherwise noted otherwise
- Paper Shroud Top/Bottom
- Fork Lift "Rear" Unloading
- Ship Via Flat Bed w/ Removable Sides (Tarped) or Closed Van
 - truck bed must be standard loading dock height 48"
- Receiving Hours 7am/3:30 pm Monday/Friday
- Drivers Should Call for Deviations 920-766-9455 ext 201, Brian Tetzlaff
- Coil Tags w/ following information: FVTD PO #, Material ID #, Material Description & Size, Coil Wt., Tare Wt., Heat #
- Any coil deviations please contact Mark Tetzlaff 920-766-9455 ext 200 or Brian Tetzlaff ext 201

Packaging Instructions:

- Material 11" Wide & Under Should Be Packaged "Eye To Sky" Per Packaging Sketch Below, Paper Shrouding Required. **Maximum Skid Weight of 12,000 lbs.**
- Material Exceeding 11" Width Should Be Packaged "Eye Horizontal" Per Packaging Sketch Below, Paper Shrouding Required. **Maximum Bundle Weight of 12,000 lbs.**
- **Each Coil Requires Circumferential Bands & A Minimum Of 3 Eye Bands**

Eye Horizontal

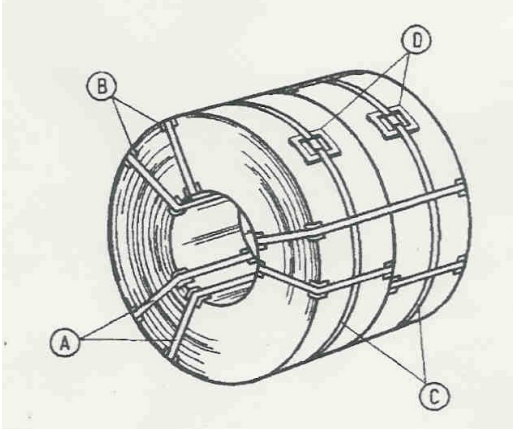

- A. Eye Bands
- B. Corner Protectors
- C. Circumferential Bands
- D. Seal Protectors

Eye Vertical

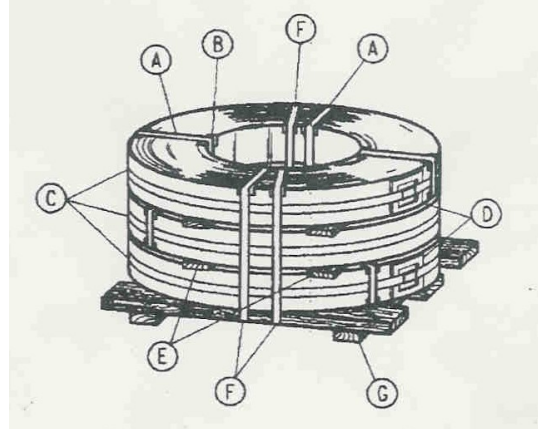

- A. Eye Bands
 - B. Corner Protectors
 - C. Circumferential Bands
 - D. Seal Protectors
 - E. 1" Separators
 - F. Securement Bands
 - G. Skeleton Platform
- * Protect Material from Lumber

Delivery Address:

1601 Badger Rd.
Kaukauna, WI 54130